

MKHD

MICROKLEAN[®] HEAVY DUTY

TACKY ROLLER CLEANING MACHINE FOR CLEANING WIDTH UP TO 60" (1524mm)

Specially formulated polymer rollers lift and transfer contaminants from your product surface to adhesive rolls.



**SLIDING CLEANING
ROLLER ASSEMBLY**

IDEAL APPLICATIONS:

- Any process where a clean substrate is crucial.
- Cleaning panels or caul plates as heavy as 300 lbs (150 kg)
- Cleaning extra wide rigid panels [from 10 MIL (250 microns) to 1" (25 mm) thick]



MKHD

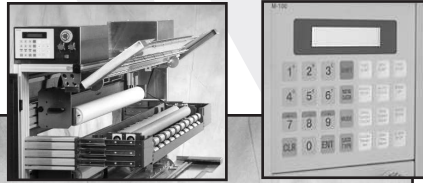

FEATURES

- Cleaning Width of 60" (1524 mm.)
- Sliding Cleaning Roller Assembly
- Pull Out Slides for Adhesive Rolls allowing fast and simple stripping of paper
- **Patented** Pneumatic System
- Operator Interface Panel provides:
 - Variable Speed (0 - 40 FPM (0 - 12 m/min))
 - Alpha numeric LCD display for alarms and information prompts
 - Panel counter
- Programmable Logic Controller enabling custom programming to meet changing needs
- Double Sided Cleaning

OPTIONS

- Custom Speed Packages up to 100 FPM (31 m/min)
- Custom Feed Line Heights
- Audible alarm for timely servicing of Adhesive Rolls
- Optional: Password protection of operation settings
- Anti-Static Bars

POWER REQUIREMENTS

- 110VAC or 220VAC
- Air Supply for (80 P.S.I)

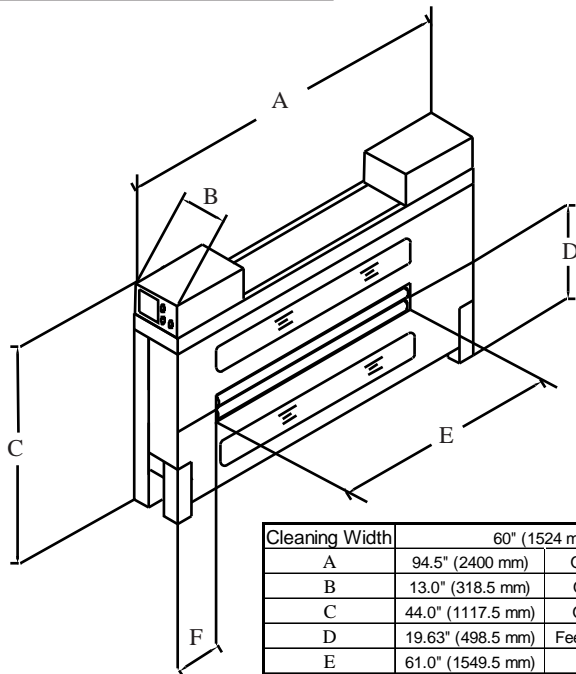

Cleaning Width	60" (1524 mm)	
A	94.5" (2400 mm)	Overall Length
B	13.0" (318.5 mm)	Overall Width
C	44.0" (1117.5 mm)	Overall Height
D	19.63" (498.5 mm)	Feed Line Height *
E	61.0" (1549.5 mm)	Pass Width
F	15.0" (381 mm)	Edge to Opening

* Feed height to be determined by end user.
Contact SDI for further information

THE CLEANING PROCESS

Special polymer rollers lift the contaminate from the panel and transfers them to the adhesive roll. When the adhesive roll becomes laden with contaminate, simply strip the outer layer exposing a new clean surface of adhesive.

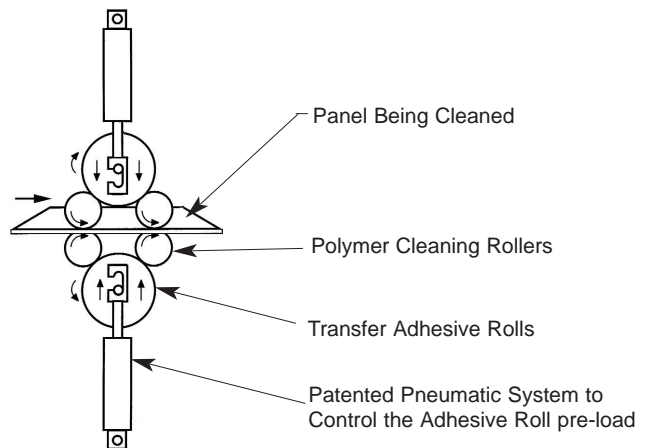

INFORMATION CONTAINED IN THIS DOCUMENT
SUBJECT TO CHANGE AT SDI DISCRETION



21 Morgan
Irvine, CA 92618
U.S.A.
Phone (949) 583-1001
Fax (949) 583-7007
www.sdionline.com